

# Vishvakarma

SEMI HYDRO-4x PAVER



Diesel Power, Power Steering, Four Steering Bogey Wheels, Variable Hydrostatic Telescopic Screed, Double Hydraulic System, Electronic Grade & Slope Control (Optional), Vibratory Screed

**\* Quality that you can rely upon \***

# Vishvakarma

## SPECIFICATION OF SEMI HYDRO-4x PAVER FINISHER

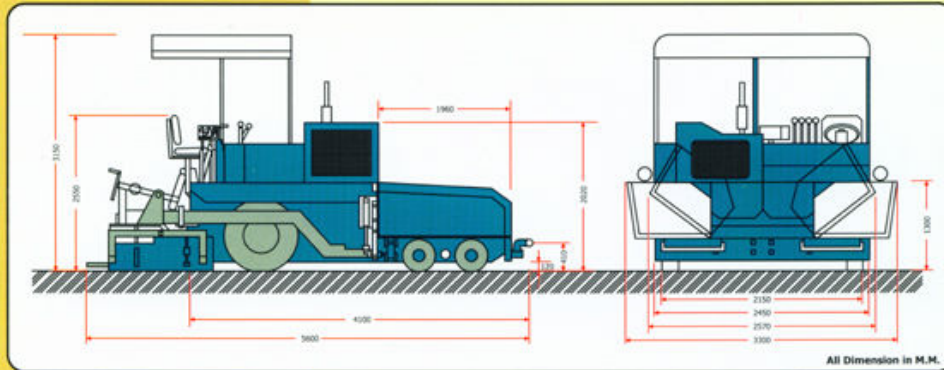

### Performance

Paving Width	: 2.5-4.00 mtrs
Paving Thickness	: Upto 10-200 mm
Paving Speed	: 4.23 M/Min
Travel Speed	: 15 Km/h (Max.)

### Tank

Fuel Tank	: 100 Ltrs
Hydraulic Tank	: 45 Ltrs
Weight	: 8700 Kgs (Approx)

### Auger Screw

Twin Mechanically Drive Abrasion  
Resistant Auger Screw

**Power Unit** : The primeover in the Asphalt Paver Finisher unit is "Kirloskar" make model - 4R1040 Diesel engine - 65 HP @ 1800 RPM, with FIP, Air Compressor, 12V alternator, self starter, 12V - 21 P Standard make battery, radiator, meters like oil pressure, water temperature, Amp. meter, hours meter, starter button, parking key, dipper switch etc.

**Variable Hydrostatic Telescopic Screed** : The main screed is consists of 2.5 mtrs (2500 mm) center fixed screed plate and other two screed plate operated by hydraulically, sliding plate on telescopic cylinder guides. It is 380 mm wide, 12 mm thickness are made of stainless steel. Two kerosene burner. The vibrator hydraulically operated, is fitted on main screed length. Variable lying of width from 2.5 mtrs to 4.00 mtrs is obtained by means of hydraulic controls.

### Hopper

Twin Hydraulic Operated folding hoppers of 4 Cu.mt capacity (Approx).  
**Grade & Slope Operated by Hydraulic System.**  
**Steering Operated by Hydraulic System.**

### Conveyer (Feeder)

Twin Lane type 80 mm pitch, mechanically drive.

### Tyres

Front - Solid Rubber Type - 4 Nos.  
Rear - 1100 x 20 - 16 Ply - 2 Nos.  
Screed - Operated by hydraulic telescopic system

### Tamper (Screed Vibrator) - Hydraulic System

Note : Specification are subject to change without notice due to development.

SINCE  
1981



**Vishvakarma** Road Equipment Co (P) Limited.

Near S. D. Chambers, Borsad - 388540. Gujarat (INDIA)

Phone : 02696 - 221317, 221217, 223297 Fax : 222926

E- mail : vreco@vishvakarma.com Website : www.vishvakarma.com